

BFC

Builders Fence Co., Inc.

HANDBOOK FOR ORNAMENTAL IRON

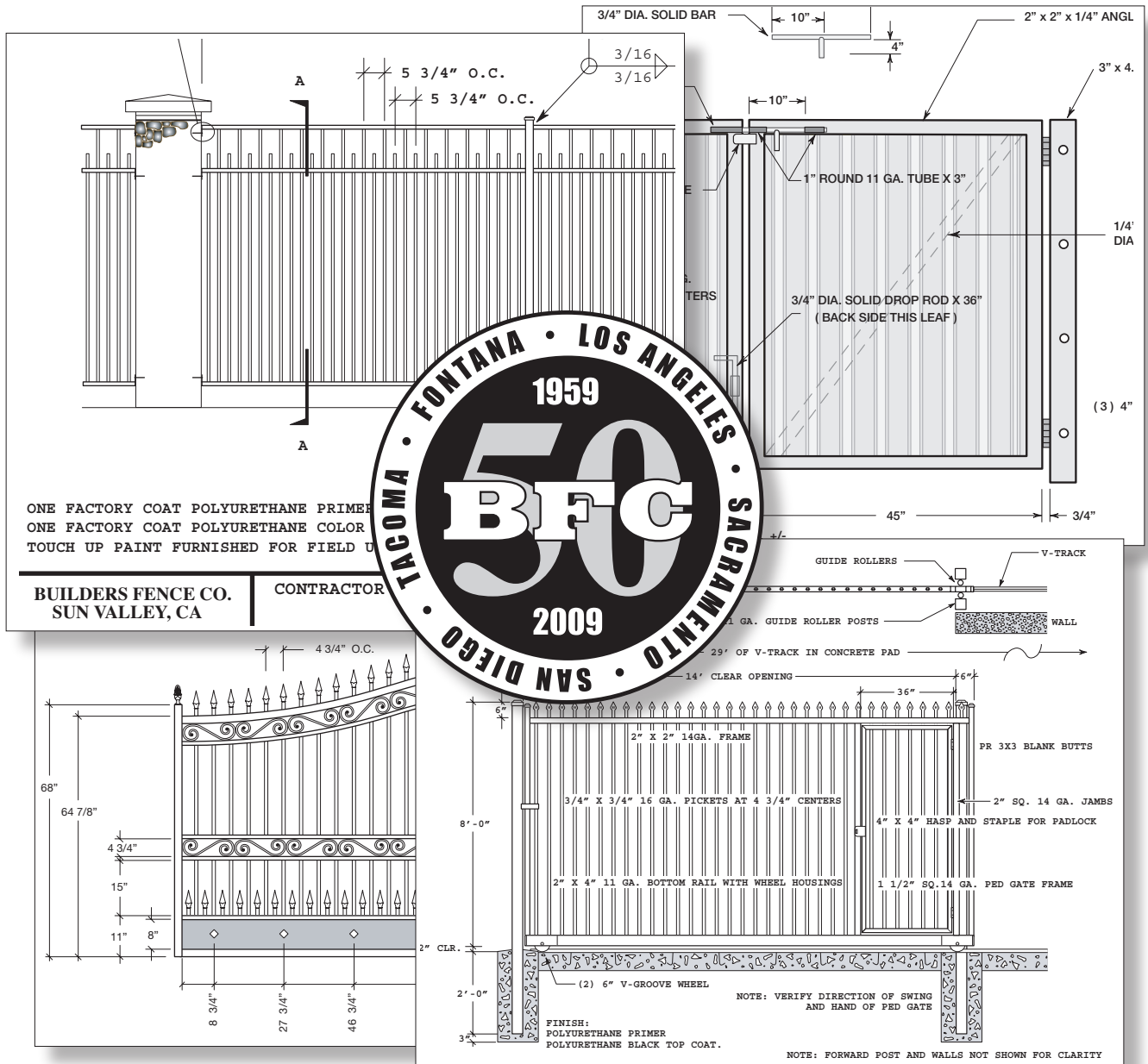

P.O. BOX 125 - SUN VALLEY, CA 91353-0125
800.767.0367 • fax 818.768.9454 • www.buildersfence.com

Builders Fence Company, Inc. reserves the right to make changes in designs and specifications or improvements on its products without notice and without incurring any obligation to incorporate these changes products previously manufactured.

The purchaser and/or user should consult governing agencies for local codes and/or requirements pertaining to the installation of the proposed fence.

<p>CORPORATE OFFICE MAILING ADDRESS</p> <p>BUILDERS FENCE CO., INC. P.O. Box 125 Sun Valley, CA 91353-0125</p> <p>(818) 768-5500 FAX (818) 768-9454 (800) 767-0367</p> <p>Internet: www.buildersfence.com e-mail: bfc@buildersfence.com</p>

BUILDERS FENCE COMPANY, INC.

TABLE OF CONTENTS

PRODUCT DESCRIPTION MATERIAL SPECIFICATIONS	2	HARDWARE KITS	14
STOCK SIZES, GROUND CLEARANCE PICKET SPACING, SWING GATE HARDWARE INFO	3	SPECIALTY HARDWARE	15
DESCRIBING THE FENCE LINE POST RECOMMENDATIONS	4	ROLLING GATE HARDWARE	16
POST LENGTHS MATERIAL FINISHES	5	ACCESSORIES AND LOCK BOXES	17
TYPICAL PANELS	6 - 7	COMBINATION LOCKS	18
INSTALLATION VARIATIONS	8 - 9	ELECTRIC RELEASE SYSTEM AND LOCKS	19
TYPES OF GATES CUSTOMIZED GATES	10 - 11	FINIALS AND SCROLLS	20
BOTTOM TRACK CANTILEVER GATE SYSTEM	12	SPECIAL CUSTOM DESIGNS	21
HEAVY CANTILEVER ROLLING GATES	13	SECURITY DOOR GUARDS	22
		CUSTOM FLAME CUTTING	23
		SHOP DRAWING SAMPLES	24 - 25
		SPECIFICATIONS	26

What is BFC ?

Builders Fence Company, Inc. is one of the United States' leading manufacturers of ornamental iron fences, gates and security products.

With four major California production and warehouse facilities (Los Angeles, Sacramento, Fontana and El Cajon) as well as a fifth facility in Tacoma, Washington, BFC supplies hundreds of thousands of ornamental iron panels for delivery nationwide.

For 50 years, Builders Fence Company has been supplying ornamental iron fence for industrial, commercial and residential applications. All BFC fence material and hardware is designed and fabricated in-plant by highly skilled experienced craftsman to meet the most demanding standards of quality control. The specialized production methods used at BFC are further assurance of enduring quality and beauty.

With this publication, we have brought together a variety of information about BFC ornamental iron products in an attempt to aid architects, engineers, designers and their associates to more clearly specify these materials and accessories on their plans.

More specific questions can be answered by a BFC product specialist. Please call.

Custom Fabrication

Builders Fence Company is one of the only manufacturers specializing in custom fabrication, working regularly with architects, engineers and landscape architects, and designers to tailor ornamental iron fence to the most demanding and unique requirements.

Send us your drawings, plans or specifications.

Product Description

Builders Fence Company, Inc. manufactures a full line of ornamental iron fencing products for any standard or custom application. From panels and gates to security products and hardware, BFC ornamental iron is the top choice of designers and architects.

Material Specifications

Unless specified otherwise, all BFC ornamental iron is manufactured with square, cold or hot-rolled steel tubing. Material sizes are listed by grade in Figure 1.

Standard Grade — (Residential)	
Rail:	1" square 16 GA.
Picket:	5/8" square 18 GA.
Heavy Grade — (Residential)	
Rail:	1 1/2" square 16 GA.
Picket:	3/4" square 18 GA.
Heavy Grade — (Commercial)	
Rail:	1 1/2" square 14 GA.
Picket:	3/4" square 16 GA.
Extra-Heavy Grade	
Rail:	2" square 14 GA.
Picket:	1" square 16 GA.
<i>See page 5 for material finishes</i>	

Figure 1: Material Specifications

Stock Styles

The BFC ornamental iron styles are available in the grades indicated by Figure 2.

	Standard Residential	Heavy Residential	Heavy Commer.	Extra Heavy
Aristocrat	•	•	•	•
Regal	•	•	•	•
Empire	•		•	
Napoleon	•		•	
Modern	•		•	•
Guardian			•	•

Figure 2: Stock Styles

Stock Sizes

Panels are manufactured according to grade in stock sizes as illustrated in Figure 3.

Lengths are manufactured as close to 8', 10' and 12' as possible while allowing for an even 4" picket spacing the entire length of the panel.

<u>Standard Grade</u>	
Height:	3', 4', 5', 6'
Length (actual):	94", 120", 143 1/2"
<u>Heavy & Extra Heavy Grade</u>	
Height:	5', 6', 7', 8'
Length (actual):	94", 118", 142"
<u>Guardian Style *</u>	
Height:	7', 8', 9', 10'
Length (actual):	94", 118", 142"
* Not recommended less than 7 feet high from finish grade	

Figure 3: Stock Sizes

Ground Clearance

The ground clearance for the various styles is shown by Figure 4.

	2"	4"
Aristocrat	•	
Regal	•	•
Empire		•
Napoleon		•
Modern	•	
Guardian	•	

Figure 4: Ground Clearance

Picket Spacing

Standard iron fencing has a stock 3 7/8" spacing between the pickets (4 1/2" o/c). Heavy fencing has either a 4" spacing (4 3/4" o/c) or a 5 1/4" spacing (6" o/c). Extra heavy fencing has either a 4" spacing (5" o/c) or a 5" spacing (6" o/c). **Other picket spacings are available to meet any custom design or specification.**

Stock Gates

Regal, Empire and Napoleon style gates have sides that extend 3/4" above the top rail and are flush on the bottom rail. Aristocrat, Modern, and Guardian styles have gates sides which extend 5 1/2" above the top rail (1/2" below pickets) and the gate side is 4" below the bottom rail.

As with chain link gates, a 4' opening gate is 44" actual width (with standard clamp-on hardware). This allows for a 4" hardware clearance.

Swing Gate Hardware

Clamp-on gate hinges are available for post sizes from 1 1/2" sq. to 2 1/2" sq. and for gate frame sizes from 1" sq. to 2" sq. See page 14 for illustration.

Weld-on gate hinges are available for all size gate leafs, ball bearing type and butt hinge type for 180° swing .

See page 15 for illustration.

Clamp-on gate latches are available for post sizes 1 1/2" sq. to 2 1/2" sq. and for gate frame sizes from 1" sq. to 2" sq.

See page 14 for illustration.

Dead bolt and lever locksets are available with steel weld-in boxes. BFC can furnish locksets in all manufacturer's standard finishes.

See page 17 and 19 for illustration.

Combination locks and exit devices are available in different styles to accommodate various security requirements.

See page 18 and 19 for illustration.

Designing Ornamental Iron Fencing

What is the Fence to do ?

Show a property line?

Protect property?

Keep animals or people in or out?

Meet municipal pool codes?

Decorate?

Once the purpose of the ornamental iron has been established, direct the customer toward the product with the best style and specifications to meet his needs. Options include complete iron fences, iron between pilasters, door guards, railings, columns and gates. Be aware of the municipal codes concerning fence requirements around pools. Self closing gate hardware can be included with our gates. Also note that scrolls in the pool fences are considered a "step" and will most likely not be passed by an inspector. Familiarize yourself with local regulations concerning front and back fence height limitations and any legislation related to door and window guards.

Describe the Fence Line

As you make a preliminary sketch of the fence line, clearly and accurately label all known dimensions of the fence plan. State all dimensions as "height by width" (H x W).

Put in enough dimensions so you can clearly understand the fence plan upon review at a later date. This will make it easier for you to place an accurate order for materials. Measure and price to the next highest foot when dimensions do not come out to even footage. Remember that each panel must be rounded up to full footage for pricing.

Posts

Designate on the ground plan where the fence is to go. The outside edge of the posts go on the property line (this establishes ownership of the fence). If the fence is to be shared, the posts go down the center of the line.

Corner and End Posts

A corner is any change of direction of the fence. This does not include gate openings, but it does include any attachments. An ornamental iron post may or may not be used as an end post.

Line Posts

Line posts are laid out between the corner posts, gate posts, end posts and ends without posts. Line posts are usually not more than 8' apart. To compute the number of line posts needed, divide the distance between end, corner or gate post by 8. This will give you the number of 8 foot panels needed for each section.

Gate Posts

Gate posts stand on either side of the gates. All gate posts are 2" square or larger, with the possible exception of gates that are less than 3' x 3'. In that case, gate posts can be 1 1/2" square.

Flanged Posts

Flanged posts are used on wood floors and decking. They may be used on other flat surfaces such as slab floors in homes. (Be aware of water and electrical lines.) The flanges are welded on squarely. Therefore, if the deck slants, the post will slant also. There are two types of post flanges available: regular decorative flanges which are 3 1/2" square with 1/4" holes and available for 1 1/2" or 2" posts; and heavy flat flanges which are 6" or 8" square x 1/4" thick with 5/8" holes and available for any size post.

POST RECOMMENDATIONS

Post Sizes

1. 1 1/2" SQUARE REGULAR for terminal, corner and line posts for fences up to 5 feet high.
2. 2" SQUARE REGULAR for terminal, corner and line post for fences up to 6 feet high; and gates with up to 15 square feet.
3. 2" SQUARE HEAVY for terminal, corner and line post for fences 6 or more feet high; and gates with 15 to 25 square feet.
4. 2 1/2" SQUARE HEAVY for gates with 25 to 40 square feet.
5. 4" SQUARE HEAVY for gates with over 40 square feet.
6. 1 1/4" SQUARE available upon request.
7. 6" SQUARE and 8" SQUARE available for special applications.

Post lengths

1. SET IN DIRT WITH CONCRETE (6" diameter hole); - 24" longer than the gross height of the fence for normal climatic conditions. (If frost line condition occurs, add height of fence to depth of frost line plus two additional inches to determine total post length).
2. CORE DRILLED AND SET IN CONCRETE SLAB; - 6" to 12" longer than the gross height of the fence.
3. FLANGED BASE (Regal, Empire or Napoleon styles); - Same as height of fence plus 3/4".
4. FLANGED BASE (Aristocrat or Modern styles); - Same as height of fence minus 1/2".

	Regular 14 GA.	Heavy 11 GA.	X-Heavy .250
1 1/2" sq.	•	•	
2" sq.	•	•	
2 1/2" sq.		•	
3" sq.		•	
4" sq.		•	•
6" sq.			•
8" sq.			•

Figure 2: Stock Styles

Post Caps

(All posts need caps)

1. Pressed steel caps are available for posts 1" square to 8" square.
2. Square posts over 8" and 2" x 4" rectangular posts are manufactured with flat caps, welded on.

Describe any special conditions for each post including core drilling, embedment in dirt, flat plate base or any other requirements.

Material Colors

14 Standard Polyurethane Colors
10 Standard Polyester Powder Coat Colors
Custom Color Matching is Available

Polyurethane paint is a high solids aliphatic two-component polyurethane coating system for use where exterior durability and color control are essential.

Material Finishes

BFC Recommended Finishes

GALVA-GUARD I, II and III provide long lasting beauty and superior corrosion protection.

GALVA-GUARD I — Recommended Paint Finish

Pre-Galvanized Tubing, Primed & Polyurethane Painted: Materials are fabricated using galvanized tubing and finished with one spray coat of high solids polyurethane primer and one spray coat of high solids gloss black polyurethane paint.

GALVA-GUARD II — For Even More Protection

Hot-Dipped Galvanized & Polyurethane Painted: After fabrication, materials are hot-dipped galvanized per ASTM-A 123 and finished with one spray coat of high solids polyurethane primer and one spray coat of high solids gloss black polyurethane paint.

GALVA-GUARD III — Recommended Powder Finish

Pre-Galvanized Tubing & Polyester Powder Coated: Materials are fabricated using galvanized tubing and finished with one powder coat of zinc-rich epoxy primer and one coat of gloss black polyester powder.

BFC Other Finishes

In addition to our galvanized steel finishes above, BFC also offers these more economical finishes for use in dry, non-corrosive environments.

POLYESTER POWDER COAT over Galvanized Tubing

Powder Coated: After fabrication, materials are power washed in an iron phosphate solution and receive one coat of gloss black polyester powder.

POLYESTER POWDER COAT over Plain Steel

Powder Coated: After fabrication, materials are power washed in an iron phosphate solution and receive one coat of gloss black polyester powder.

POLY-PRO +, over Plain Steel

Polyurethane Painted: After fabrication, materials are power washed in an iron phosphate solution and receive one spray coat of high solids polyurethane primer and one spray coat of high solids gloss black polyurethane paint.

TWO COAT ENAMEL over Plain Steel

After fabrication, materials are power washed in an iron phosphate solution and receive one spray coat of rust inhibitive primer and one spray coat of gloss black enamel.

ONE COAT ENAMEL over Plain Steel

After fabrication, materials are power washed in an iron phosphate solution and receive one coat of gloss black enamel. This one coat system is intended as a primer. It is recommended that a top coat be applied.

Standard Styles Illustrated

Illustrations 1 through 5 on the following pages show the Standard Styles available in BFC Ornamental Iron. Picket location and spacing is indicated for each style.

For finish options, see page 5 — MATERIAL FINISHES

Aristocrat Style

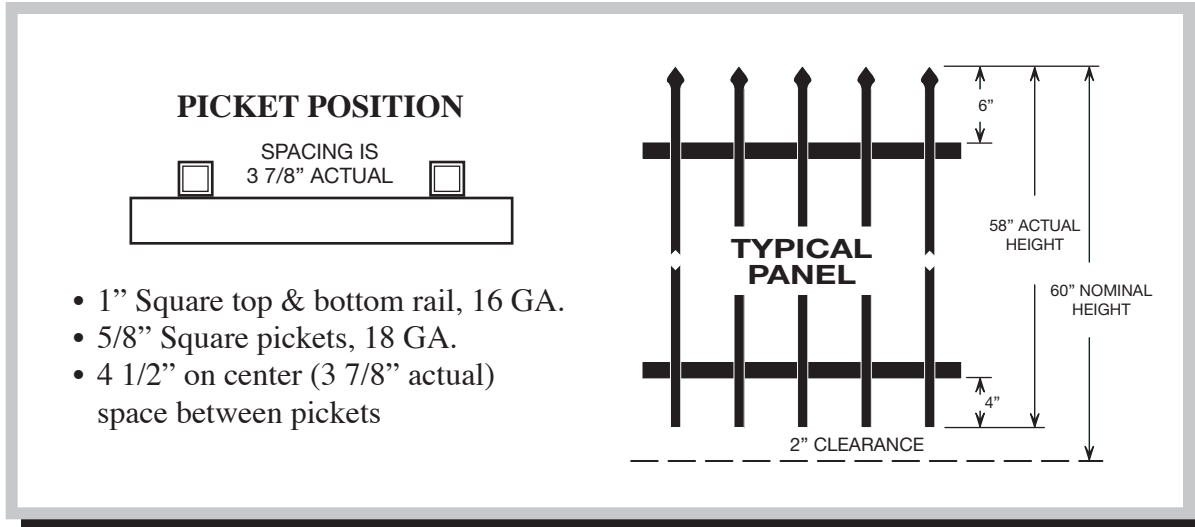

Illustration 1: Typical Standard Aristocrat Panel

Modern Style

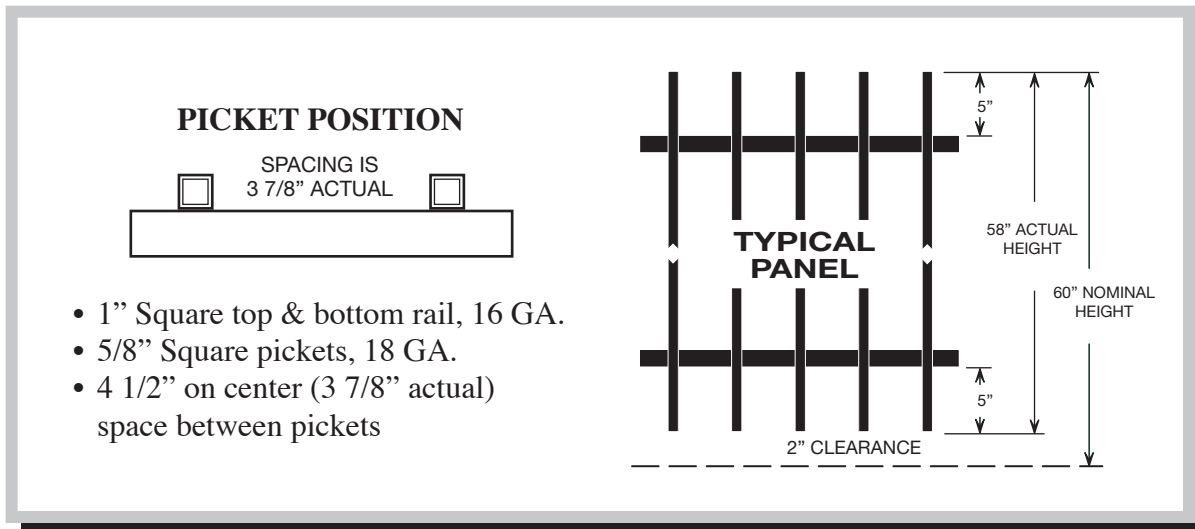

Illustration 2: Typical Standard Modern Panel

For other grades see Figure 1 on page 2.

Standard Styles Illustrated

Regal Style

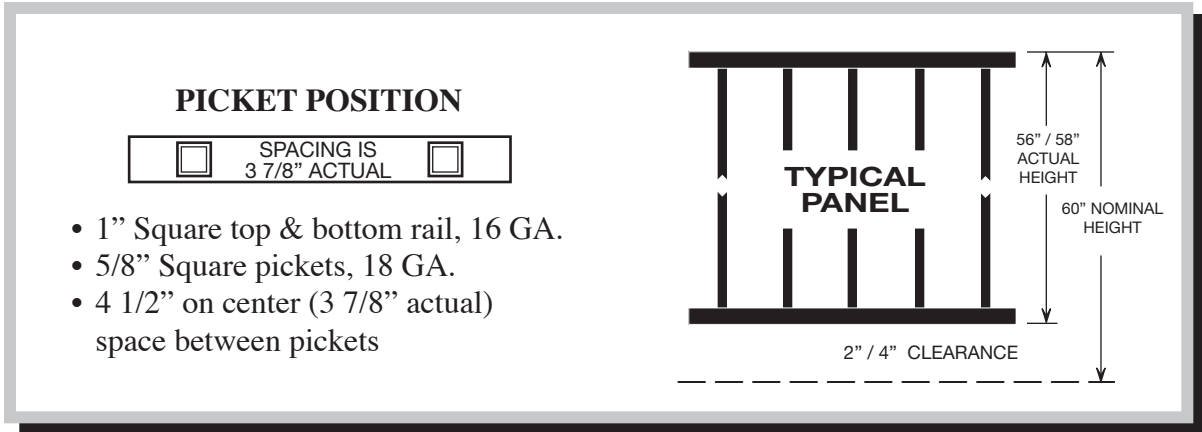

Illustration 3: Typical Standard Regal Panel

Empire Style

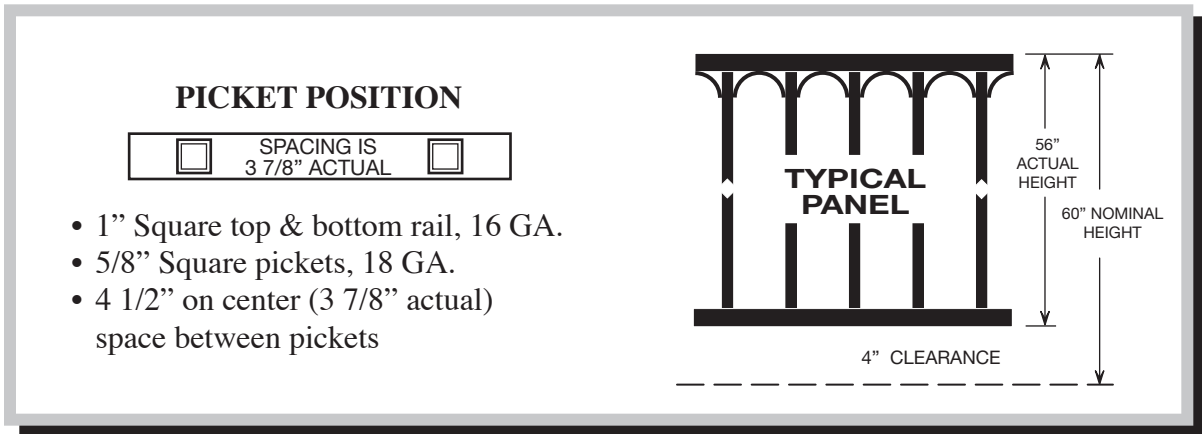

Illustration 4: Typical Standard Empire Panel

Napoleon Style

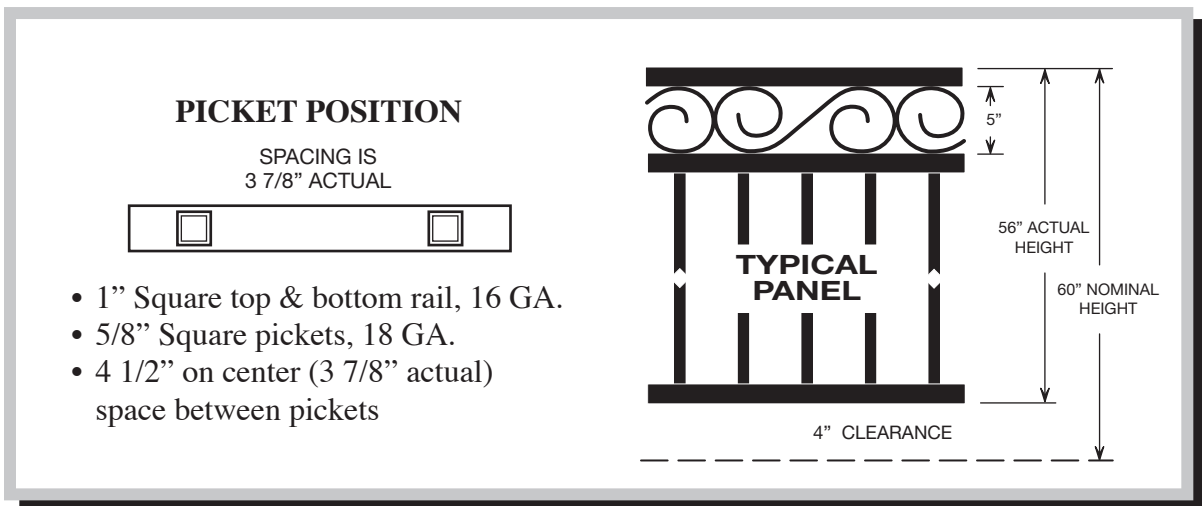

Illustration 5: Typical Standard Napoleon Panel

Installation Variations

Elevation Changes

Elevation changes require a post. In other words, a level fence that starts up or down a slope must have a post where the slope starts and ends. Likewise, if a fence changes height (as in step height changes), there must be a post at the point of each height change.

Note any slope the fence must cross. Is it uphill or downhill.

Attachment

Point out any place the fence will attach to existing posts, walls or structures and note how the fence is to be attached. Indicate what the fence is to be attached to and the location for the attachment.

Pilasters

For pilasters further than 8' apart, a center leg may be put in the middle for support. If the distance is more than 10' between pilasters, or the fence is greater than 5' in height, it is recommended that a post be used in the center.

Special Situations

List any special conditions that might need consideration, such as children or small dogs.

Custom Fabrication

At Builders Fence Company, we manufacture a comprehensive line of standard fences, gates and hardware in sizes, styles and grades that will fit most designs and plans. **In addition, we are one of the few manufacturers that specializes in custom fabrication, working regularly with architects and designers to tailor ornamental iron fence to the most demanding and unique requirements.**

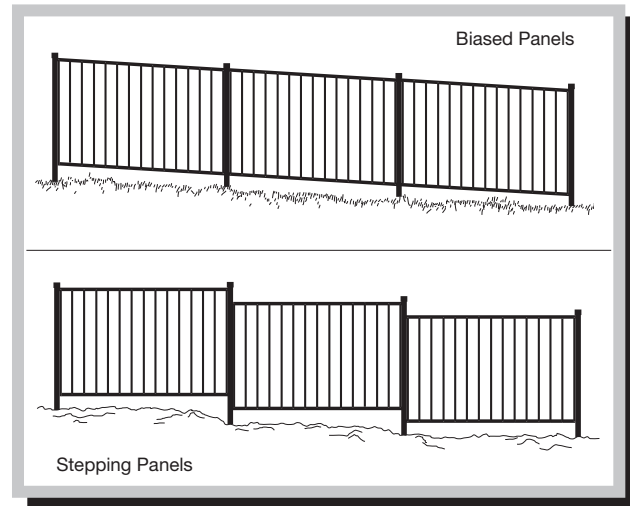

Illustration 6: Biased and Stepping Panels

BFC will modify any of our regular styles, or manufacture an entirely new look based on your specifications to accommodate particular problems or designs. For more complete information on BFC custom fabrication capabilities to keep you a step ahead, contact one of our representatives.

Installation Variations

Biased Panels

Biased panels are made on an angle to match the ground contours. Such a panel is used when the customer does not want the fence to step, or when over the length of the panel, there is more than a 4" drop (for Regal, Napoleon or Empire styles) and more than a 2" drop (for Aristocrat and Modern styles) in question. Measure the length of the biased panel to the next foot and be sure to include a post at the top and the bottom of the bias. Include the dimensions shown in illustration 7.

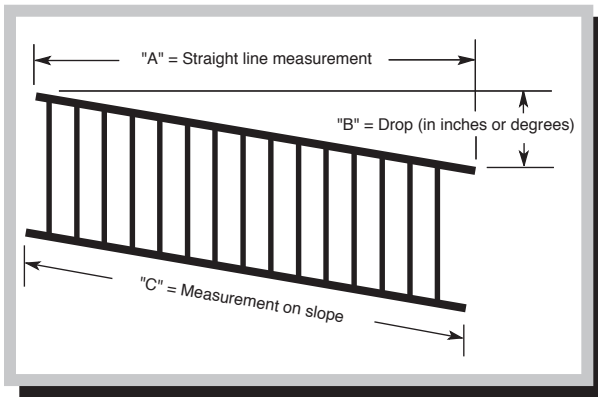

Illustration 7: Hillside or Biased Panel

Tapered Panels

Tapered panels allow for a fence with a level top line while adjusting for changes in ground elevation. Be sure to note the height of both ends of the tapered panel as viewed from outside the fence line.

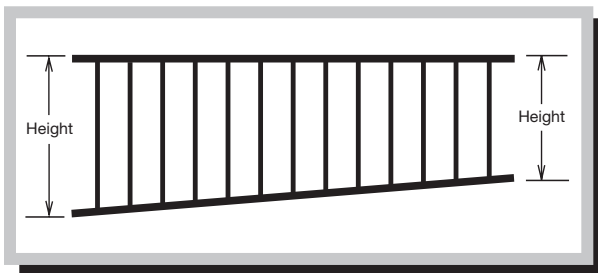

Illustration 8: Tapered Panel

Curved Panels

Curved panels are used to soften a corner or to match an existing design or to create a soft flowing fence line. Be sure to include the measurements indicated by illustration 9.

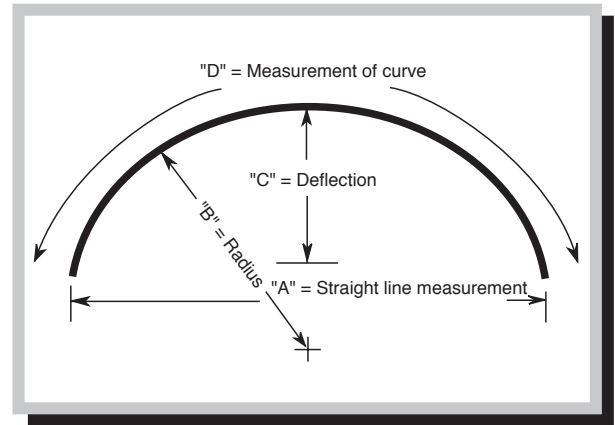

Illustration 9: Curved Panel Dimensions

Notches

A notch is a situation where a corner of a gate or a panel is cut out to facilitate installation around a low wall, or other small obstacle the fence will have to fit around. Fully describe any cut outs in the fence.

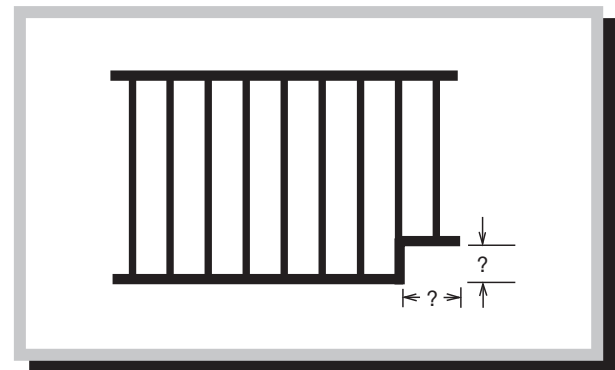

Illustration 10: Notched Panel

BFC Gates

Gates (available in all styles)

For swing gates (single and double) indicate on which side the gates are hung and the direction of opening (as viewed from outside the fence line looking in). For slide gates, indicate the direction of travel for opening. For either type of gate, be sure to indicate the measurements of the required opening (height by width).

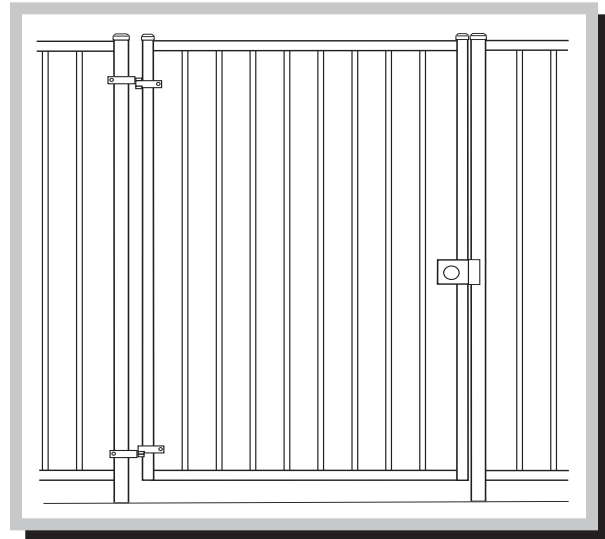

Illustration 11: Typical Heavy Regal Single Swing Gate with Lock Box

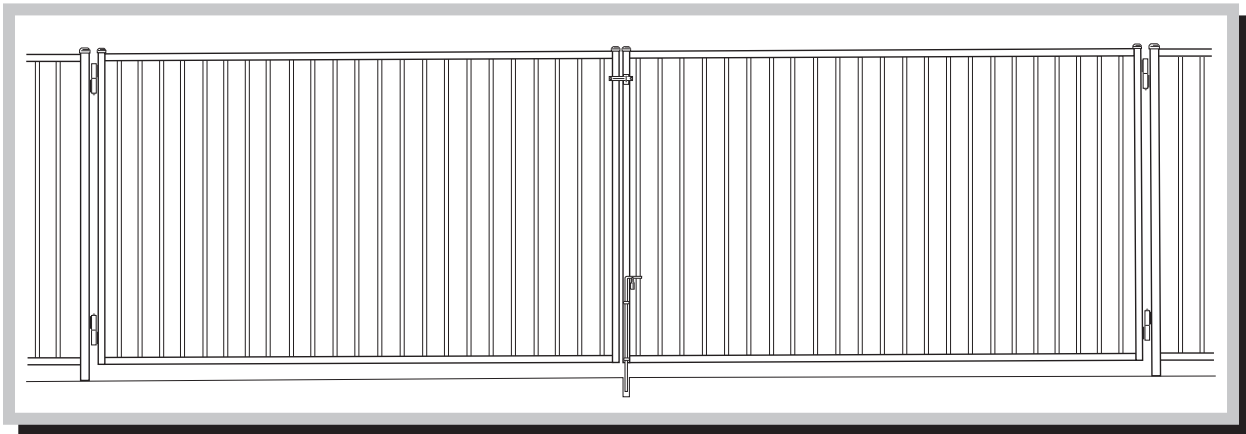

Illustration 12: Typical Heavy Regal Double Swing Gate

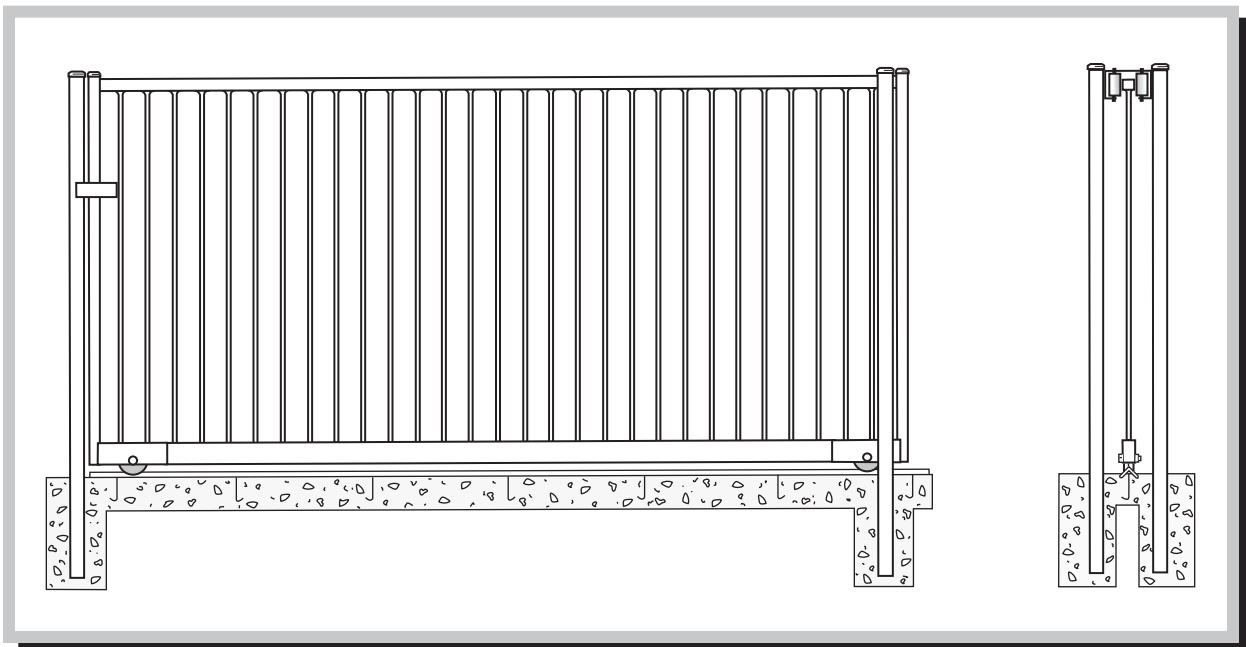

Illustration 13: Heavy Regal Style Roller Assembly Slide Gate, slides right to open



Illustration 14: Double Gate

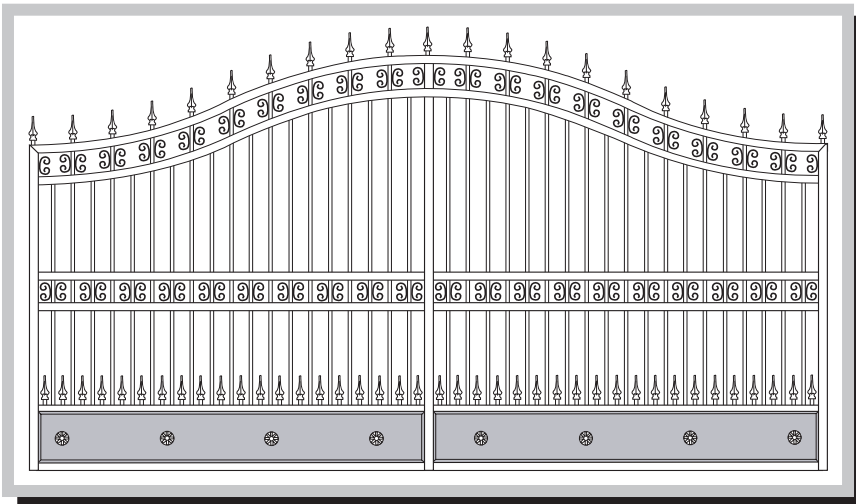

Illustration 15: Single Gate

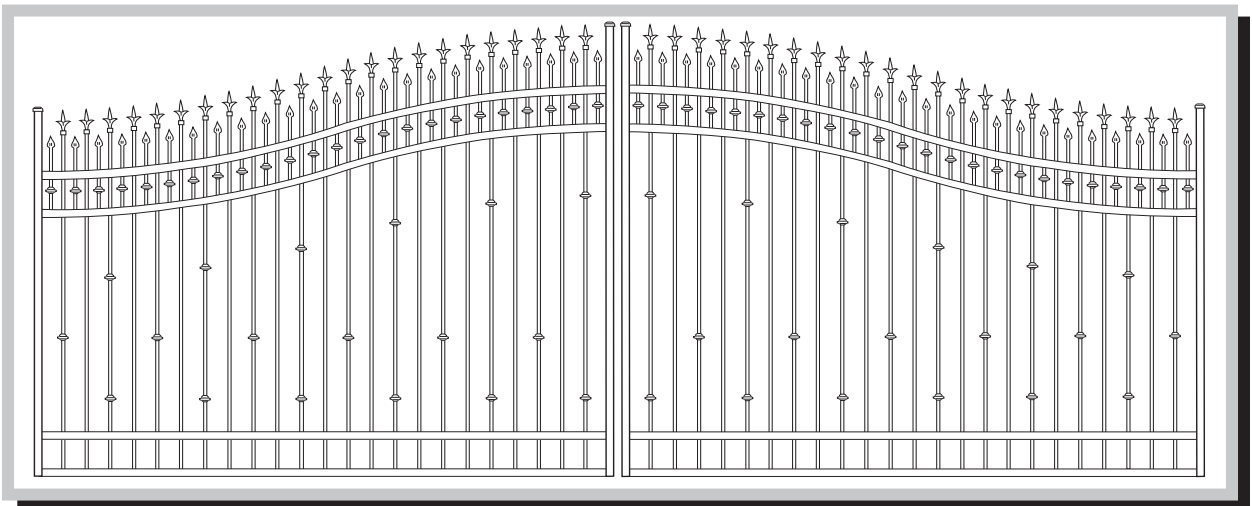

Illustration 16: Typical Large Double Swing Gate

BFC Gates

Customized Gates

These are just a few samples of the beautifully designed gates that BFC can manufacture to your specifications. We provide detailed drawings with any required special instructions.

Options can include a variety of castings, scrollwork, plates, lettering, accessories, etc.

Send your sketch or ideas to your sales representative.

BFC Gates

Cantilever Rolling Gate

The gate is made approximately 50% longer than the opening.

Component Grades

PICCOLO

— For Medium Size Gates —

33 foot maximum opening,
2,200 lb. maximum load.

GRANDE

— For Large Size Gates —

66 foot maximum opening,
4,400 lb. maximum load.

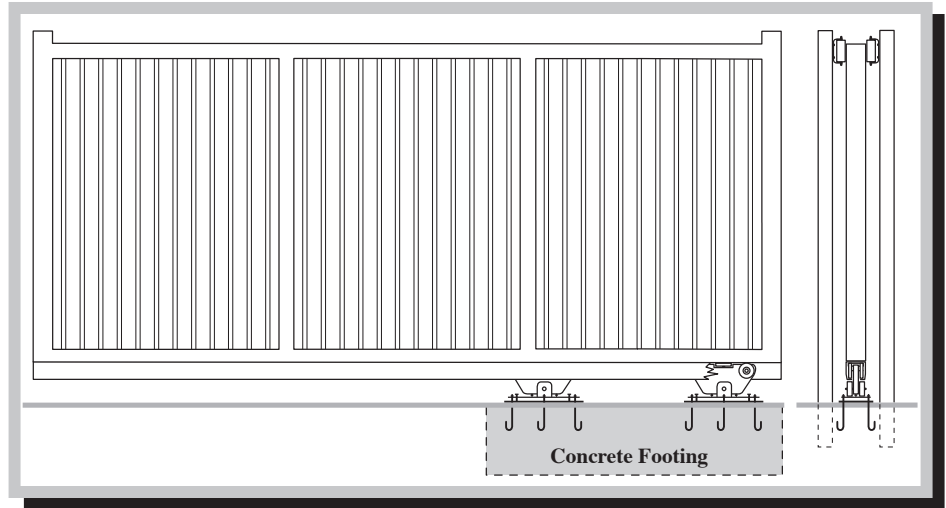
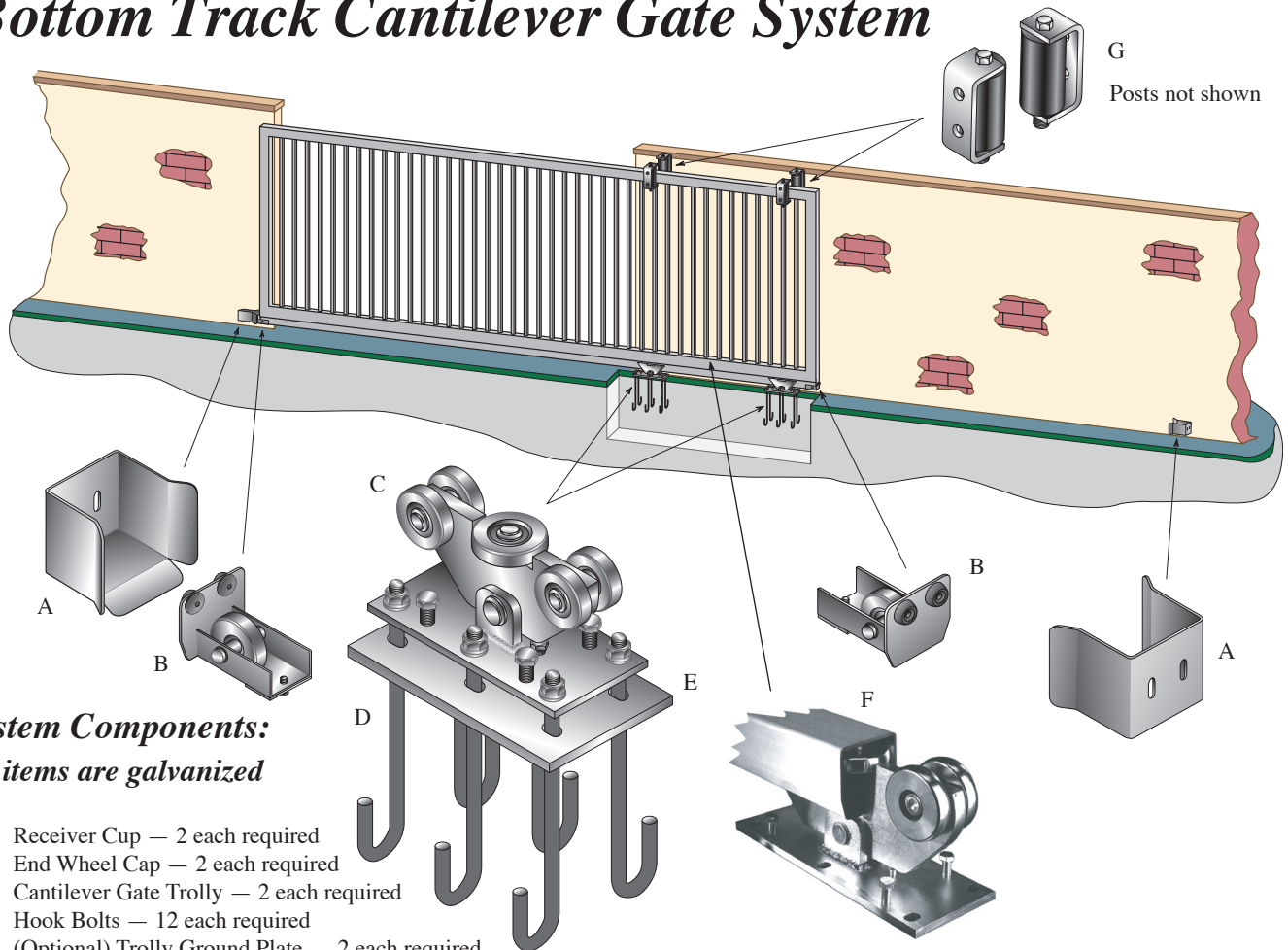

Illustration 17: Heavy Regal Cantilever Gate

Bottom Track Cantilever Gate System



System Components:

All items are galvanized

- (A) Receiver Cup — 2 each required
- (B) End Wheel Cap — 2 each required
- (C) Cantilever Gate Trolley — 2 each required
- (D) Hook Bolts — 12 each required
- (E) (Optional) Trolley Ground Plate — 2 each required
- (F) * Cantilever Bottom Track — 1 or more required
- (G) BFC Type II (over head roller set) — 2 each required
* Sold in full lengths only

Illustration 18: Heavy Regal Cantilever Gate with System Components

Bottom Track Cantilever Gate System

Cantilever Rolling Gate System Components:

Each Gate Requires

- 1 or more Cantilever Bottom Track *
- 2 each Cantilever Gate Trolley
- 2 each (Optional) Trolley Ground Plate
- 12 each Hook Bolts
- 2 each Receiver Cup
- 2 each End Wheel Cap
- 2 each BFC Type II (over head roller set)

Component Grades

PICCOLO

— For Medium Size Gates —

- * 236" long track sold in FULL LENGTHS ONLY.
- 33 foot maximum opening (2,200 lb. maximum applied load, must be calculated.)
- All items are galvanized —

GRANDE

— For Large Size Gates —

- * 236" long track sold in FULL LENGTHS ONLY.
- 66 foot maximum opening. (4,400 lb. maximum applied load, must be calculated.)
- All items are galvanized —

See page 25 for a typical shop drawing showing a more detailed view of the components of a cantilever gate system.

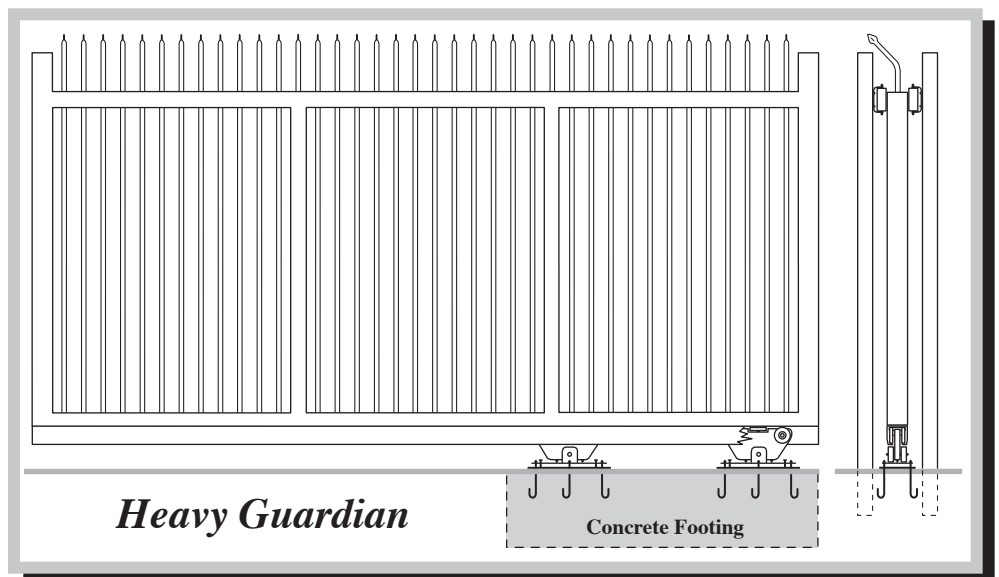
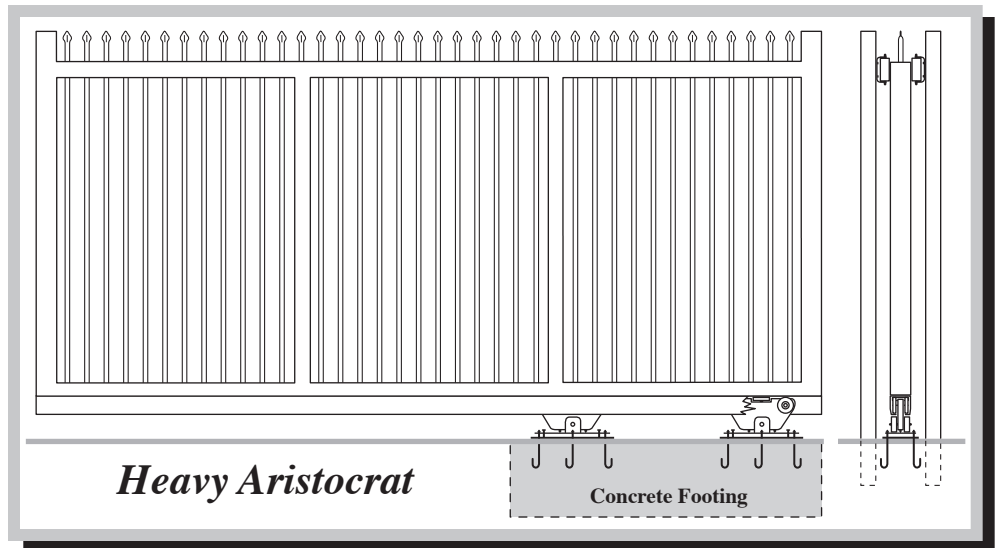
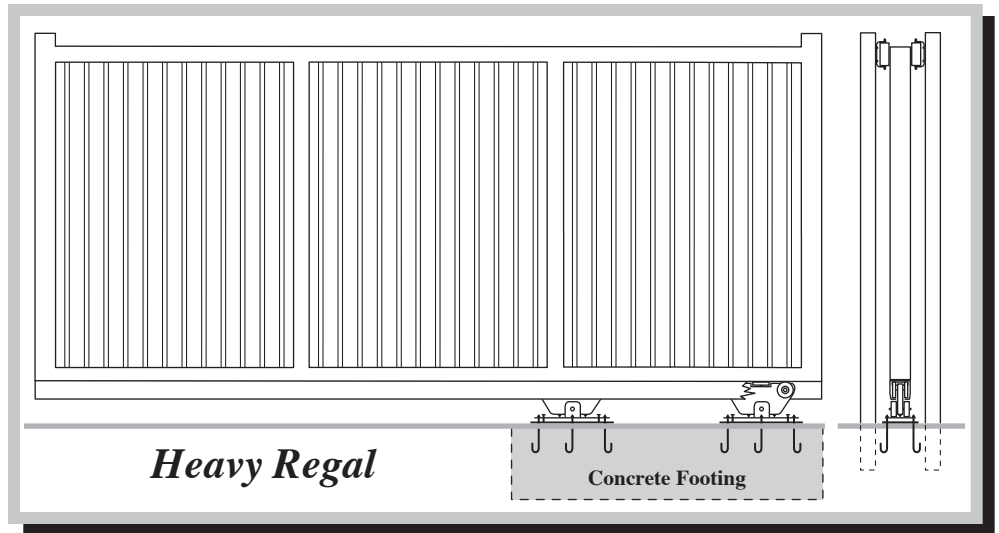
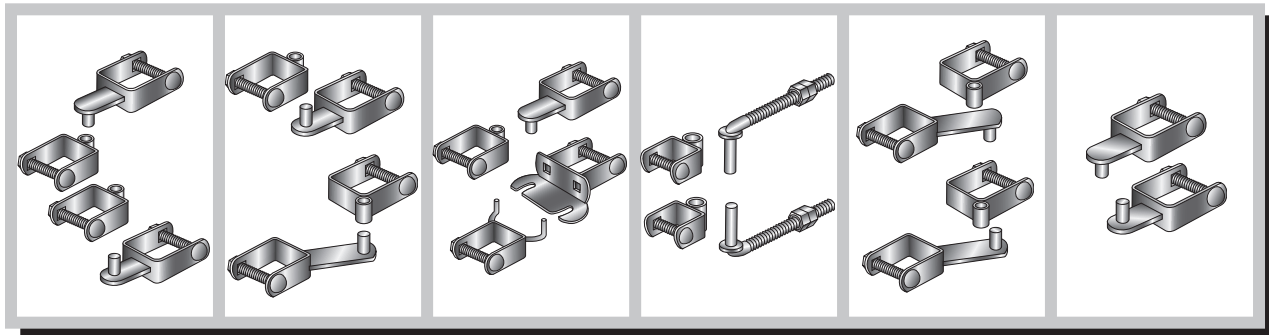

Illustration 19: Heavy Cantilever Rolling Gates

BFC Basic Clamp-on Swing Gate Hardware Kits



Kits A1 - A9
to steel post

Kits B1 - B9
self-closing gravity

Kits C1 - C9
two-way
self-closing

Kits D1 - D5
drilled post

Kits E1 - E9
180 degree

Kits F1 - F7
post side

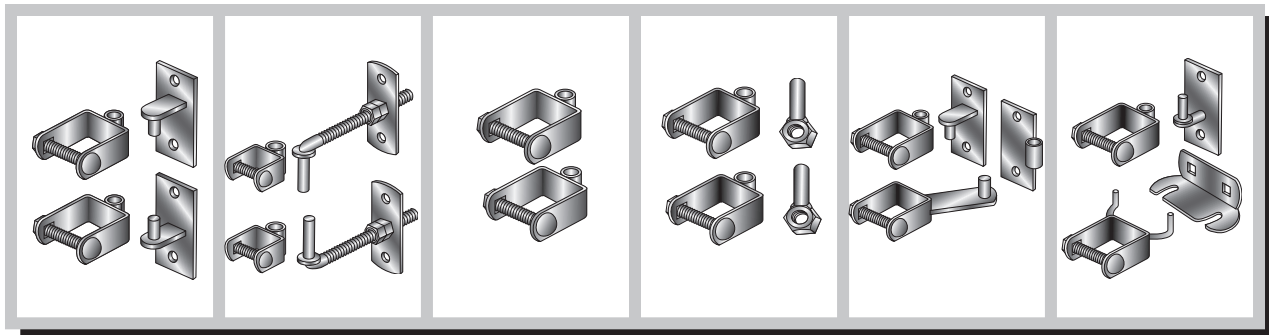

Kits G1 - G6
to masonry

Kits H1 - H3
adjustable

Kits J1 - J6
gate side

Kits K1 - K6
embedded
bolts

Kits L1 - L2
self-closing
to masonry

Kits L3 - L4
two-way
to masonry

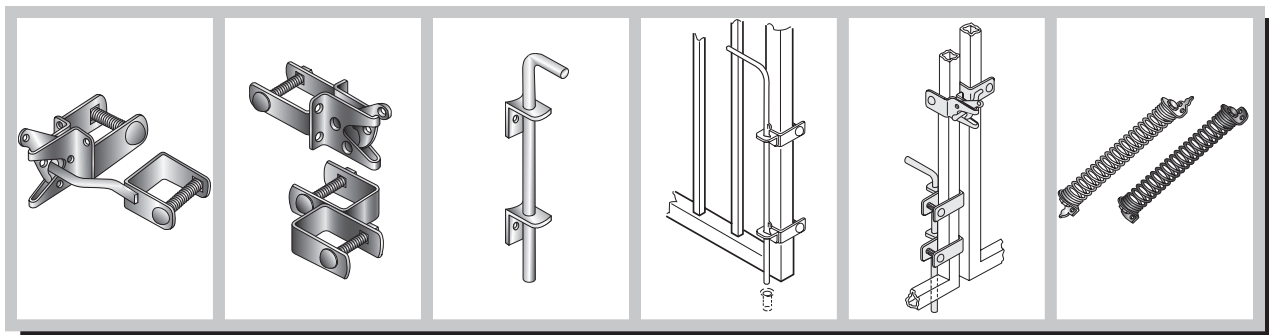

Kits M1 - M7
striker
bar latch

Kits N1 - N4
slide gate latch

Kits P1
weld-on
drop rod

Kits P2 - P3
clamp-on
drop rod

Kits R5 - R6
residential
D/D assembly

Gate Spring
self-closing

Illustration 20: Hardware Kits

Swing Gate Hardware

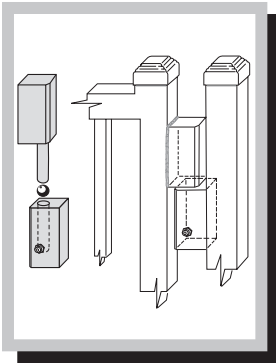

Ball Bearing Hinge
(small, medium & large)

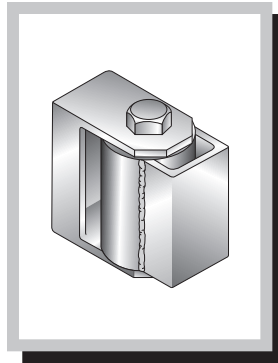

Roller Bearing Hinge
(extra heavy duty)

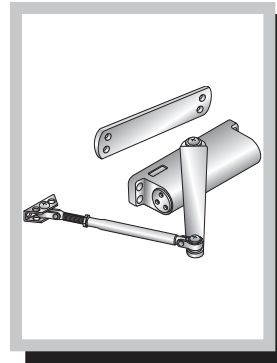

Hydraulic Closers

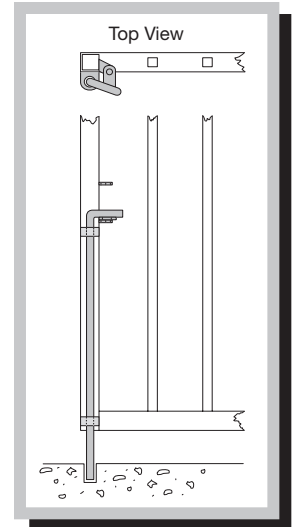

Heavy Lockable
Drop Rod

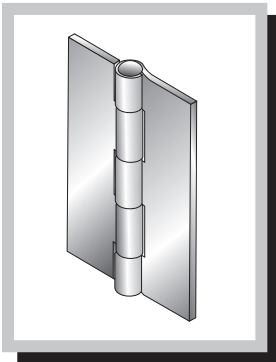

Self-Closing Butt Hinge

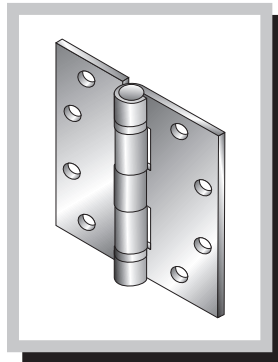

Blank Butt Hinge

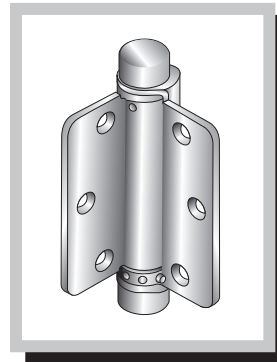

Ball Bearing Butt Hinge



Combination Locks

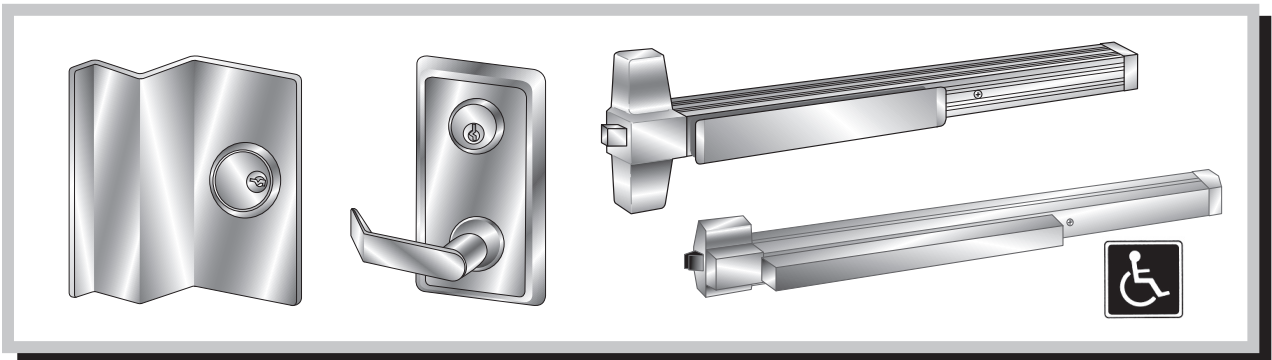

Exit Devices

Rolling Gate Hardware

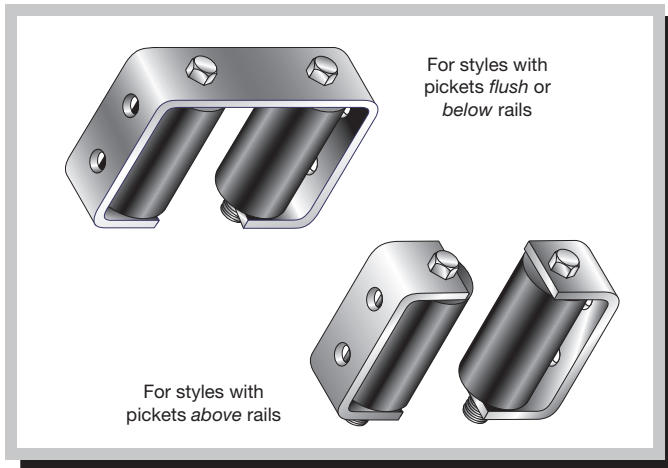

Slide Gate Roller Assembly

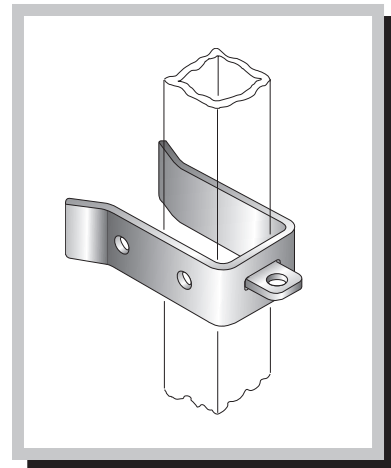

Industrial Slide Gate Latch

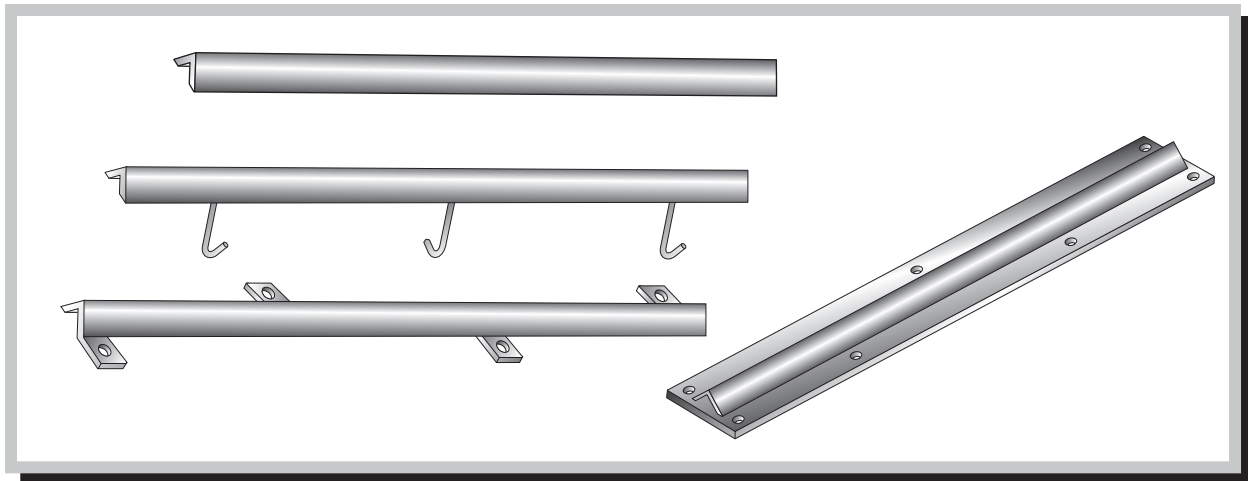

Galvanized V-Track — for use with V-Groove Wheel

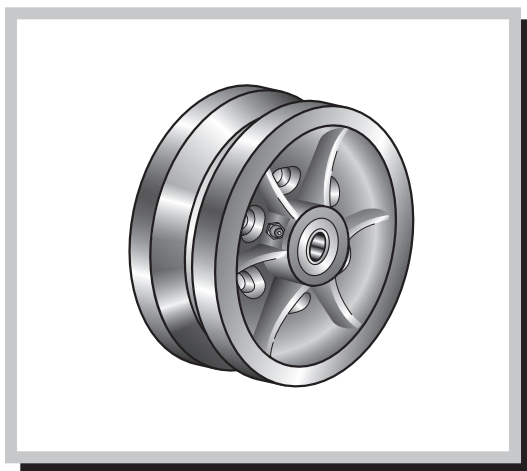

V-Groove Wheels
Malleable Iron

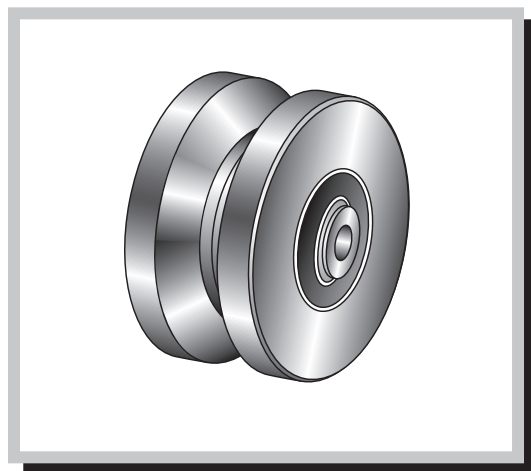

V-Groove Wheels (solid steel)
up to 5,000 lbs. capacity per wheel

Accessories

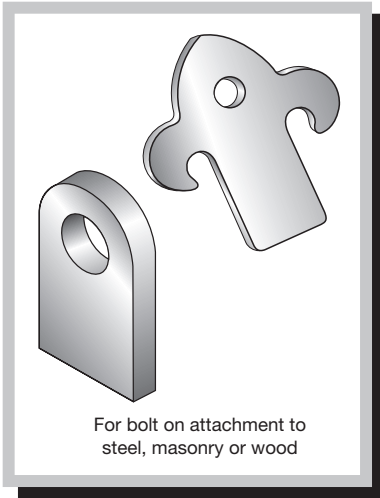

Mounting tabs (weld in shop or field)

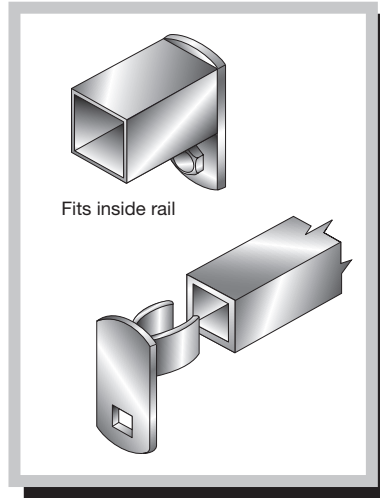

Mounting Brackets

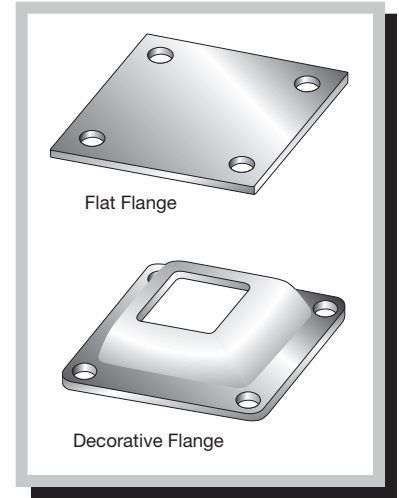

Post Flanges

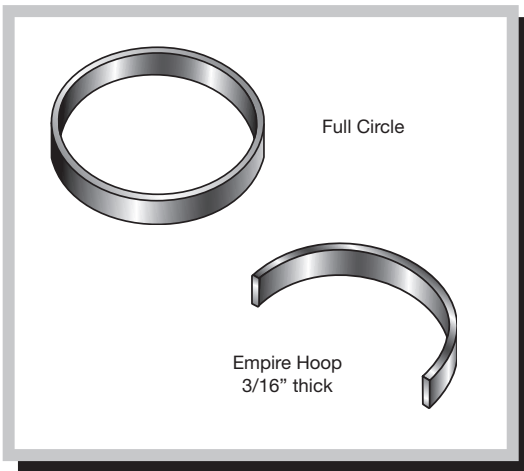

Circles & Hoops

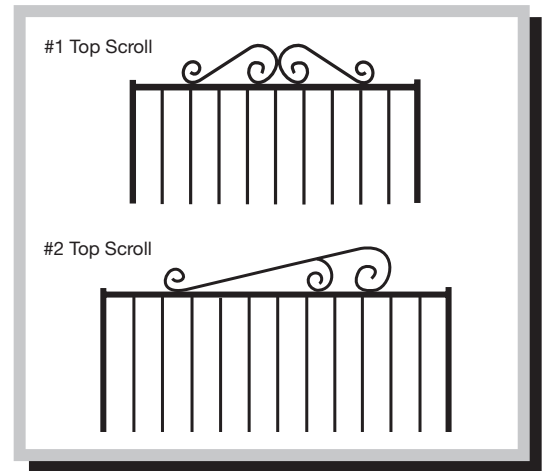

Top Scrolls

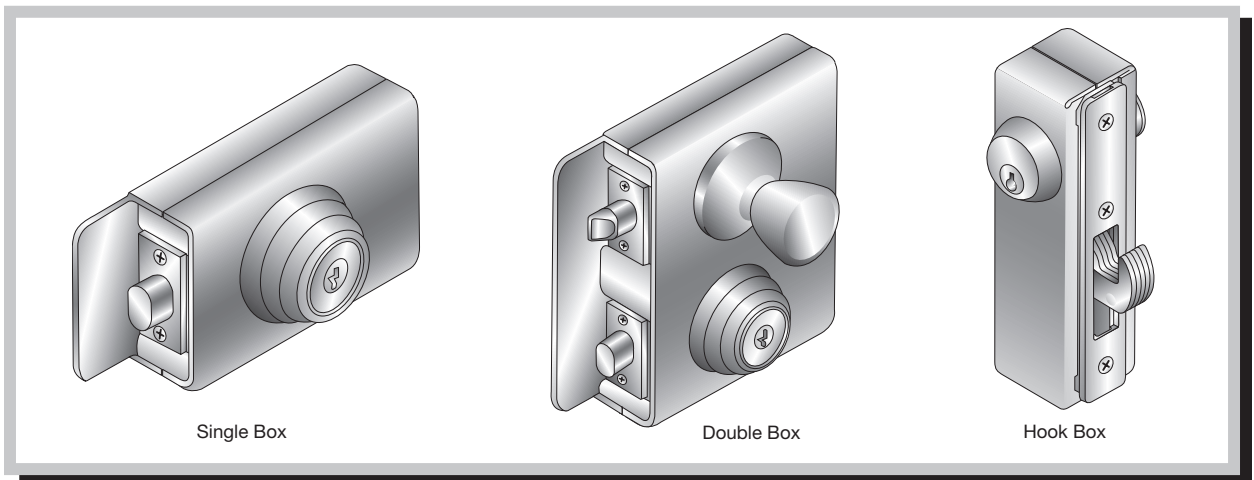

Single, Double & Hook Lock Boxes

Locks



Trilogy T2 Series



*Trilogy Lock ETDL
(outside trim for exit device)*



Simplex 5020

Combination Locks

These are just a few samples of the beautifully designed locks that come in a variety to choose from.

Some of the specifications include; master and user codes, key bypass, vandal and weather-proof, easy to install and suitable for outdoor applications.



Unican EE/1011

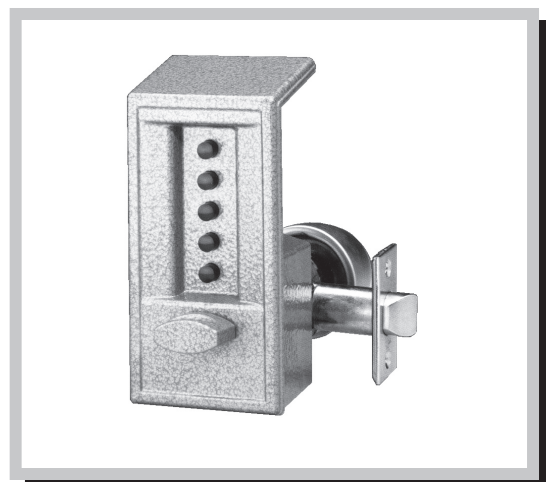

Unican 6200

Locks

Electric Release System

This kit includes: A release lockbox, electric release, stepdown transformer and a electric push-button.

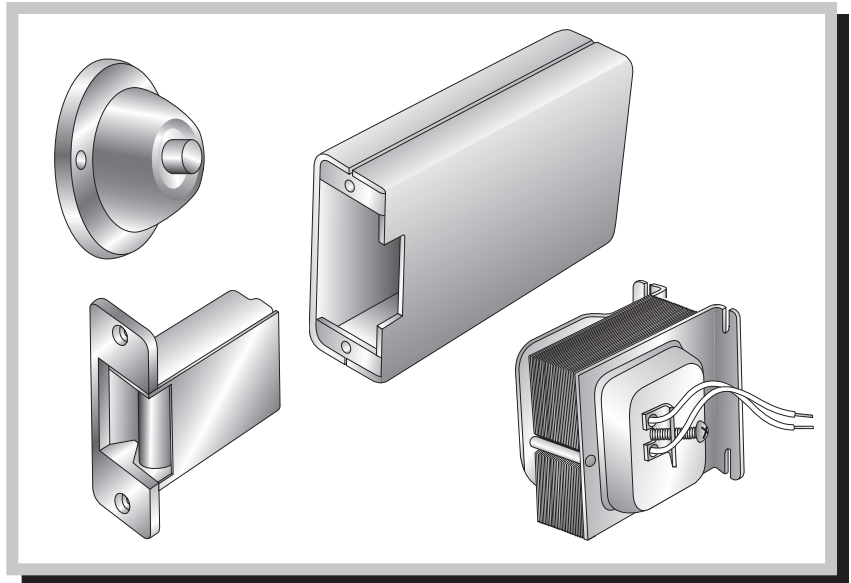

Electric Release System

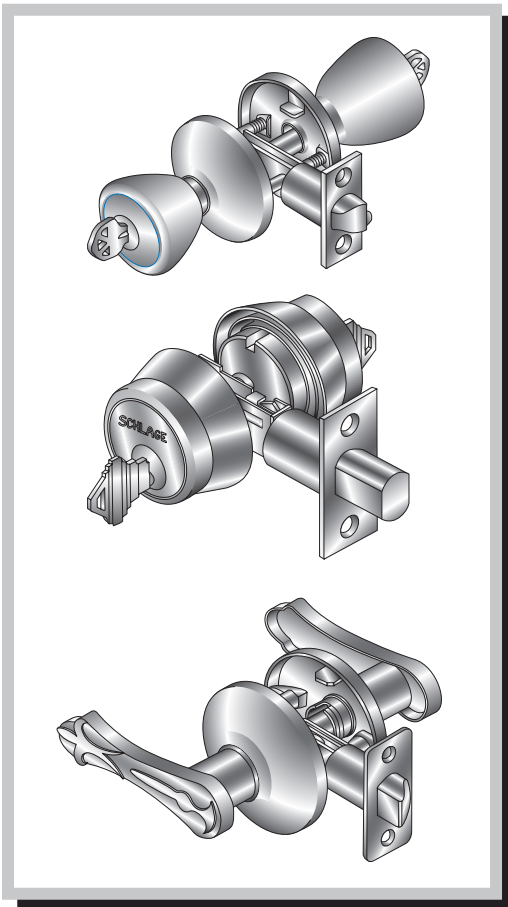

Schlage & Kwikset Deadbolt and Passage Locks

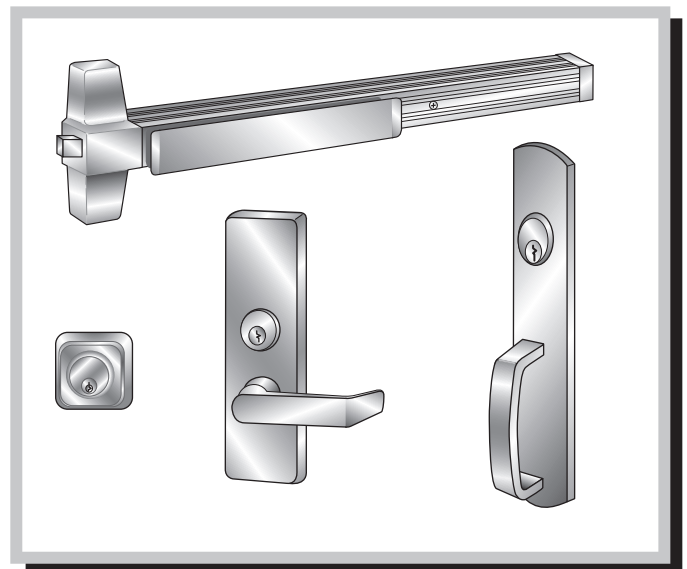

Exit Devices and Trims

Exit Devices and Lock Sets

Many styles of locks and exit devices are available, along with weldable steel boxes. Gates are furnished with lockbox and plate prepared per device templates.

Illustration 25: Locks & Accessories

Accessories

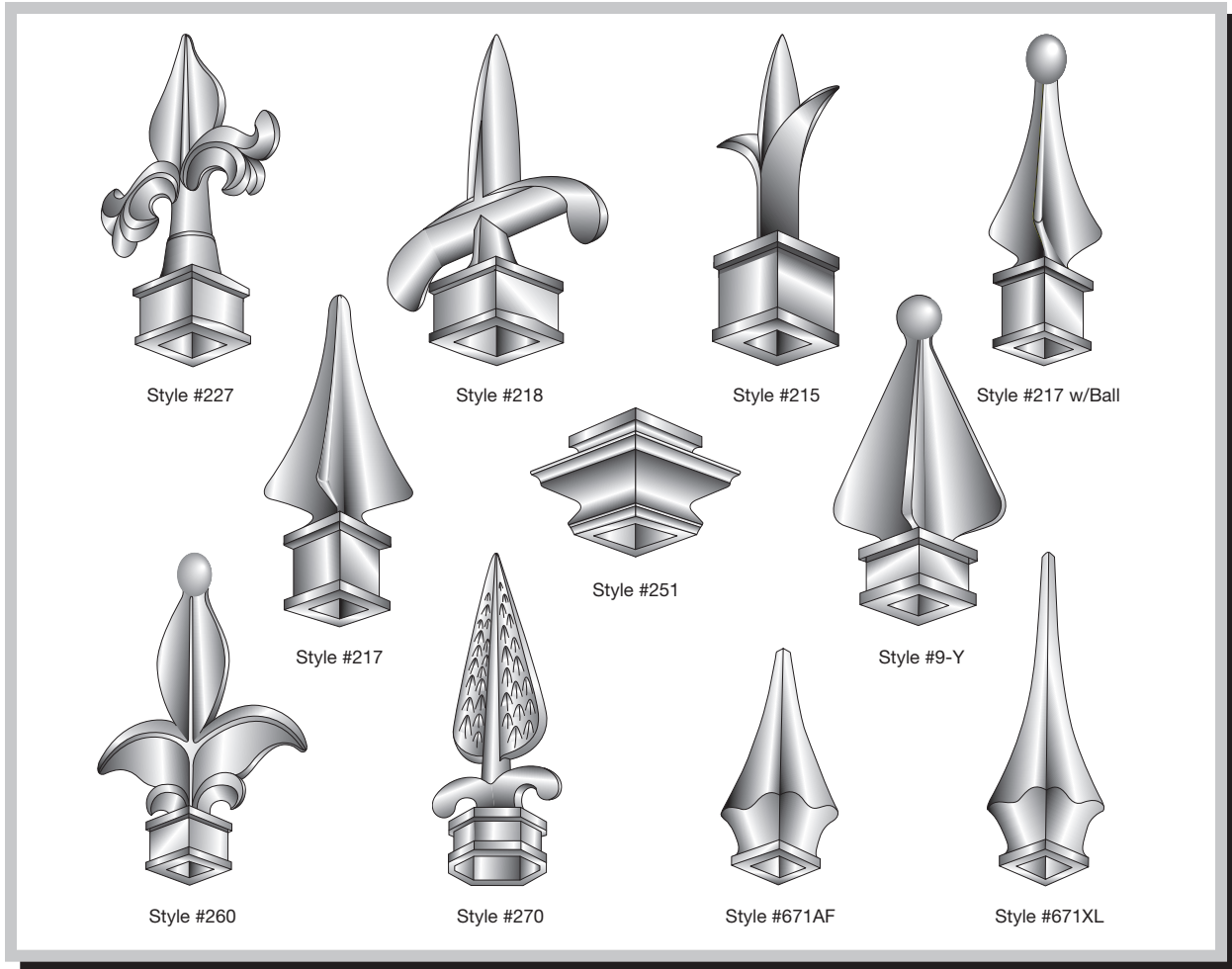
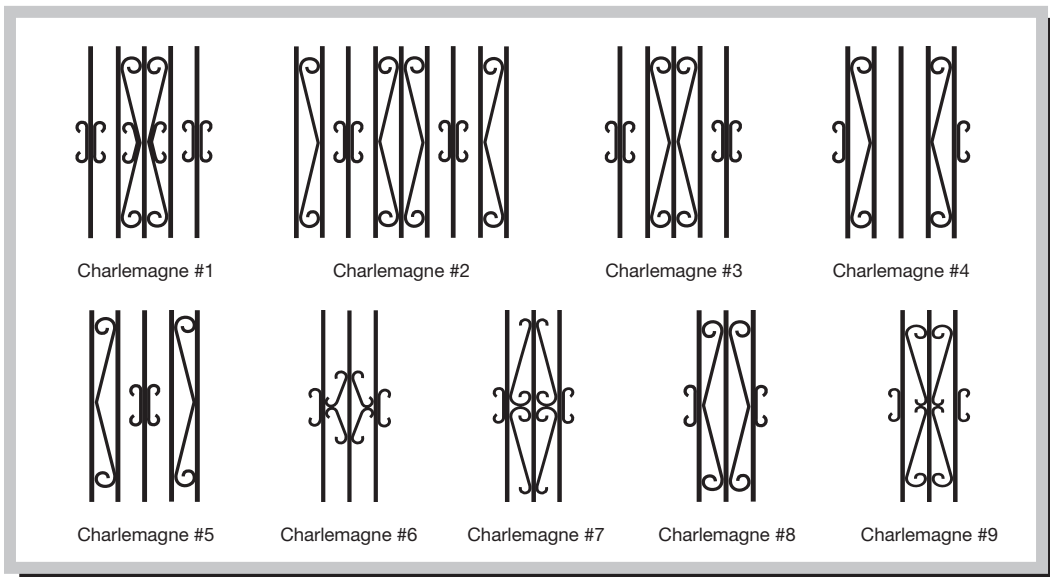

Illustration 26: Castings for 1/2" square, 5/8" square and 3/4" square pickets



Special Custom Designs

Beautiful & Elegant Variations

Available in residential and commercial grades.

We will gladly modify any of our styles to accommodate your particular problems or designs, or we will fabricate an entirely new look based on your own specifications.

- 001 **Aristocrat** style with alternating height pickets
- 002 **Aristocrat** style with double top rail
- 003 **Aristocrat** style with cast iron knuckle every other picket
- 004 **Aristocrat** style with doggie pickets
- 005 **Aristocrat** style with arching pickets
- 006 **Aristocrat** style with swooping pickets

- 007 **Empire** style with cast iron finials and steel scroll work

- 008A **Regal** style with horizontal castings
- 009 **Regal** style with double top rail and "C" scrolls
- 010 **Regal** style with vertical castings
- 011 **Regal** style with two rows of cast iron knuckles every other picket
- 012 **Regal** style with double top and bottom rails with circles between rails

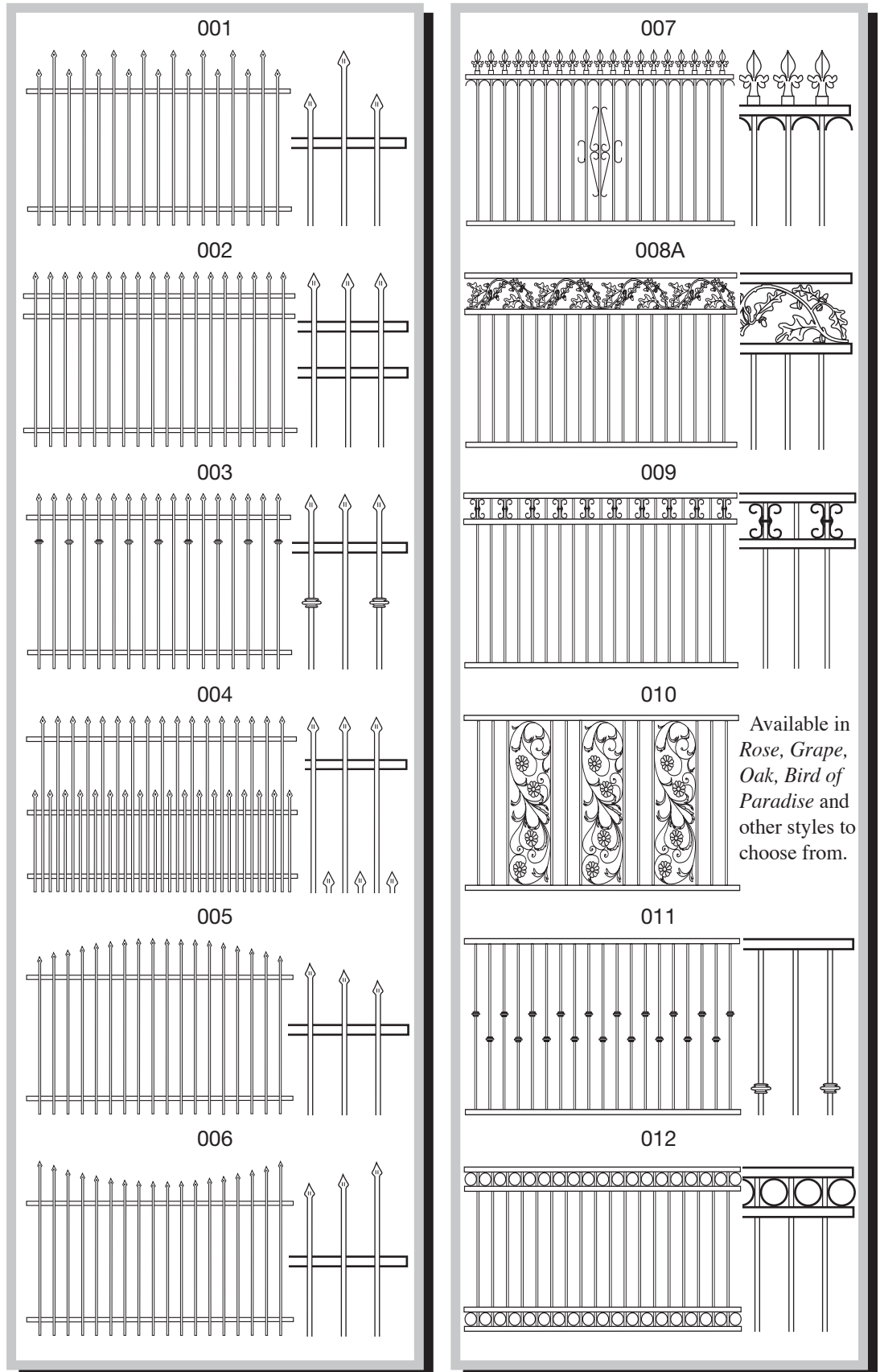

Available in Rose, Grape, Oak, Bird of Paradise and other styles to choose from.

Illustration 28: Various Styles

Security Door Guards

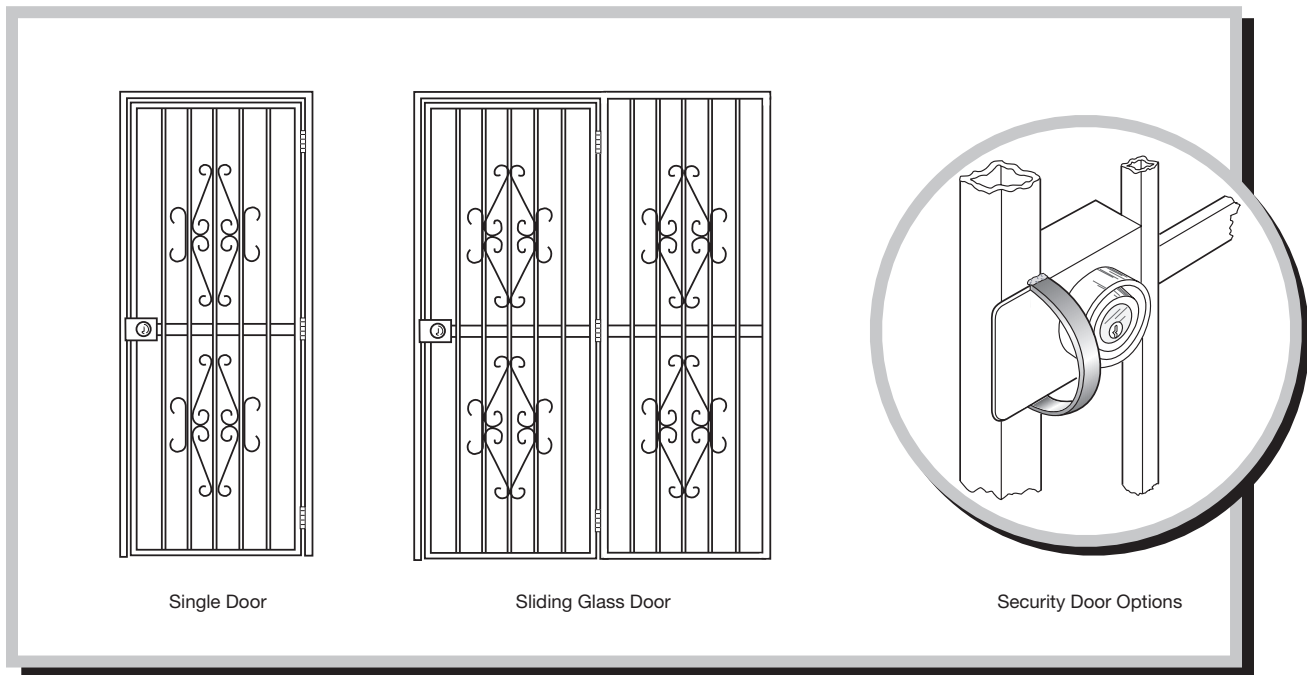

Illustration 29: Security Doors

Door Guards

Door guards are Regal Style and fully designed to specifications.

Optional Features Include:

- Perforated Metal Strip*
- Fly Strip*
- Expanded Metal, 1/2" #16*
- Passage Latch, (handle or manual)*
- Deadbolt Lock Sets*
- Lockguard*
- Solid Pickets*
- Security Door Handle*

Security Door Specifications:

- 1" x 1 1/2" 16 GA. tubular steel outer frame
- 1" x 1" 16 GA. tubular steel inner door frame
- 5/8" square 18 GA. tubular steel vertical pickets at 4 1/2" on center
- After fabrication, materials are power washed in an iron phosphate solution and receive one coat gloss black enamel
- Two sets of decorative scrolls per door (3/16" x 1/2")
- Heavy duty lock box with single or double cylinder deadbolt lock (1" throw)
- 1" x 1 1/2" frame drilled six 3/8" holes (or specify mounting method)
- Six 5/6" x 4" one-way screws

Laser Cutting Designs

Custom Flame Cutting

3/16" thick up to 2" thick steel

*Fax or mail your design
for a quotation*



**A VARIETY OF STANDARD STYLES
OF LETTERS AND NUMBERS
IS AVAILABLE AT YOUR REQUEST**

A **B** *C* **D** **E** **F** *G*

1 **2** **3** **4**



Illustration 30: Plate Designs

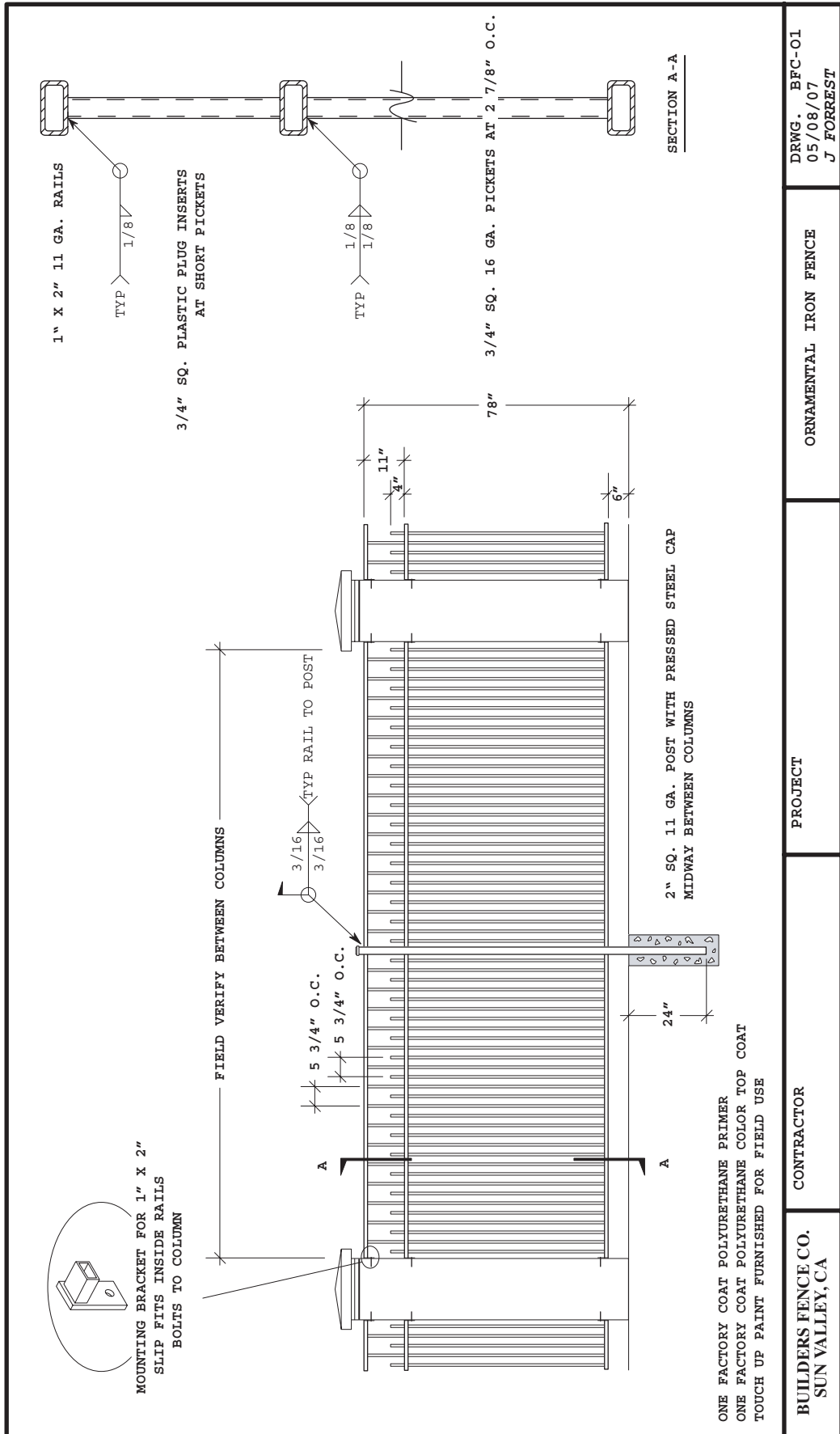

SAMPLE SHOP DRAWING

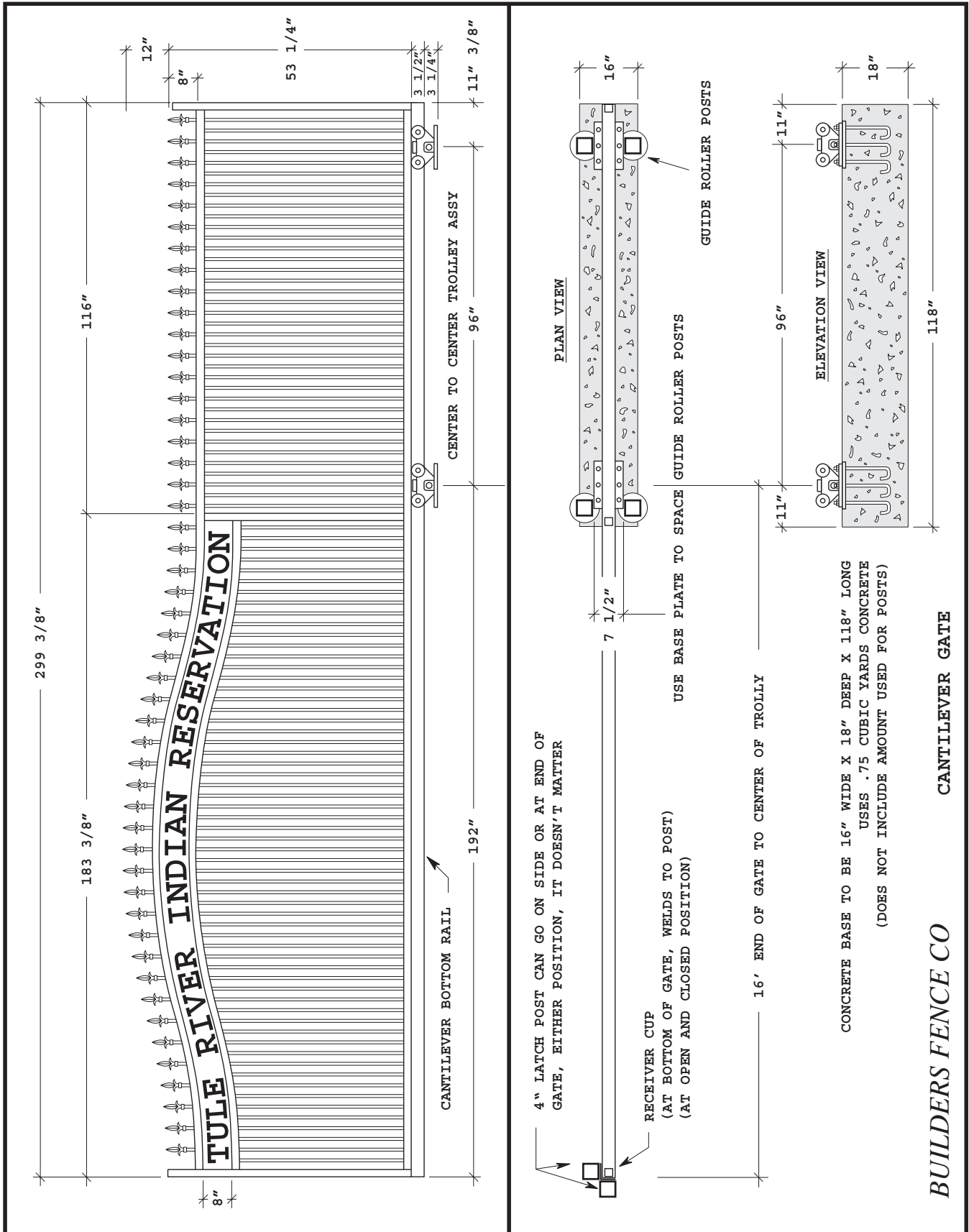

Illustration 32: Typical Shop Drawing

SPECIFICATIONS

B F C IRON

PART 1 — General

1.01 WORK INCLUDED

This specification covers ornamental iron fence materials including ornamental iron gates, posts and hardware.

1.02 RELATED WORK

Section ___ - Earthwork

Section ___ - Concrete

Section ___ - Painting

1.03 SYSTEM DESCRIPTION

The manufacturer shall supply a complete ornamental fencing system including all components defined herein (fence panels, posts, gates and hardware).

1.04 QUALITY ASSURANCE

The contractor must be familiar with the construction methods and materials involved in ornamental iron fencing.

1.05 REFERENCES

ASTM A 36 - Structural Steel, Bars, Flats, and Shapes

ASTM A 123 - Zinc (Hot-dipped Galvanized) Coatings

ASTM A 500 - Steel Structural Tubing in Rounds and Shapes

ASTM A 513 - Electric-Resistance-Welded Carbon and Alloy Steel Mechanical Tubing

1.06 SUBMITTALS

Submit the manufacturer's shop drawings and literature prior to installation. Approved shop drawings shall become the basis for acceptance of the work.

1.07 DELIVERY, STORAGE, & HANDLING

Deliver to the job site materials in good condition and properly protected against damage to factory-finished surfaces.

Store materials in a clean, dry location and in such a way as to avoid damage, especially from dust, chemicals and moisture in the air by covering with protective material. Handle materials carefully on the job site to protect factory finishes.

1.08 WARRANTY

Builders Fence Co., Inc. hereby certifies that it manufactures the ornamental iron fencing and gates in accordance with specifications and/or shop drawings supplied by BFC. Builders Fence Co., Inc. assumes the responsibility of providing products meeting BFC's prescribed specifications. Local environmental factors vary widely, therefore BFC does not guarantee that its product will perform in any defined manner in any specific environment. Damage to coating due to

shipment and installation is to be expected and must be adequately touched up or repainted immediately after occurrence by installer to meet original specification standards.

PART 2 — Products

2.01 ACCEPTABLE MANUFACTURERS

The ornamental fencing system shall be manufactured by:

Builders Fence Company, Inc.

P.O.Box 125

Sun Valley, CA 91353-0125

1•800•767•0367

2.02 MATERIALS

A. Pickets, rails, and posts shall be manufactured from tubing meeting the requirements of ASTM A 513 or A 500 Grade B.

B. Solid steel bars, flat plates and shapes shall be manufactured from steel conforming to the requirements of ASTM A 36.

C. Pickets for gates shall be of the same size and style as those in the fence panels. Frames for gates shall be of sufficient size and thickness to provide adequate support without sag. Adjustable trussing may be required. Gate hardware shall be supplied by the manufacturer and shall be of sufficient size and capacity to support the gate specified.

2.03 FABRICATION — General

A. Steel used in the manufacturing of panels, gates and posts shall conform to the ASTM standards specified and shall be new prime material.

B. Panels, gates and flanged posts shall be of welded construction. No wire rods, screws or rivets shall be accepted to attach pickets to rails. Layout and welding shall be done by experienced craftsmen. Welds shall be made by the gas metal arc method and welds shall be neat, clean and of the sizes indicated on the drawings. All flush welds shall be ground smooth.

C. After fabrication panels, gates and posts shall be power washed in a phosphoric acid solution, rinsed and dried.

Finish shall be chosen from one of the following:

BFC GALVA-GUARD I

BFC GALVA-GUARD II

BFC GALVA-GUARD III

BFC POLY-PRO +

PART 3 — Execution

3.01 PREPARATION

A. The contractor shall layout the new fence in

accordance with the fence construction plans, shop drawings, and all applicable requirements and codes.

B. The contractor shall verify any grade changes or surface irregularities.

C. Discrepancies between the approved shop drawings and field conditions must be approved by the architect or engineer prior to proceeding with the installation.

3.02 INSTALLATION

A. Fence posts shall be set plumb and level at spaces shown on the drawings. Footings shall be of the sizes indicated. Post caps shall be as indicated on the drawings.

B. Fence panels shall be welded or bolted to the posts. Field welding of rail to the post shall be a complete 360 degree (all four sides) and shall be the size indicated on the drawings. Welds shall be cleaned and coated with a primer the same day the welding is performed. Bolted connections shall use bolts and tabs of the size indicated on the drawings. After tightening bolt, threads shall be peened.

C. Gates shall be installed plumb and level and shall be the sizes and style indicated on the drawings. The contractor shall install any gate stops that may be required. Any padlock provisions or strikes shall be field attached to assure alignment. The contractor shall lubricate the hinges, rollers and other gate hardware after installation.

D. All field welds and any abrasions to factory coatings shall be thoroughly cleaned, re-primed and touched up by the contractor with paint of the same quality, color and gloss of that used by the manufacturer.

3.03 CLEANING

A. The contractor shall clean job site of excess materials.

B. Post hole excavations shall be scattered uniformly away from the posts or removed as directed.

C. Concrete splatter shall be cleaned from exposed posts.

web: www.buildersfence.com

email: bfc@buildersfence.com

see us at
Sweets.com

© 2008 BUILDERS FENCE CO., INC.

BUILDERS FENCE COMPANY, INC.
P O BOX 125 • SUN VALLEY, CA 91353-0125
1-800-767-0367 • FAX 818-768-9454

8530 UNSWORTH AVE. • SACRAMENTO, CA 95828
13111 DAHLIA ST. • FONTANA, CA 92337
8937 SAN FERNANDO RD. • SUN VALLEY, CA 91352
1265 N. CUYAMACA ST. • EL CAJON, CA 92020
10010 PORTLAND AVE. • TACOMA, WA 98445